

# OWNER'S MANUAL | MANUEL DE L'UTILISATEUR MANUAL DEL PROPIETARIO | HANDBUCH | MANUALE DELL'UTENTE



MODEL / MODÈLE / MODELO / MODELL / MODELLO : PBV24CB  
PART / PIÈCE / PARTE / TEIL / PARTE : 10806

# CHAMPION™

## CHARCOAL BARREL SMOKER

IMPORTANT, READ CAREFULLY, RETAIN FOR FUTURE REFERENCE. MANUAL MUST BE READ BEFORE OPERATING!

## FUMOIR BARIL POUR CHARBON DE BOIS

IMPORTANT, PRENEZ CONNAISSANCE DE CE DOCUMENT ET CONSERVEZ-LE POUR RÉFÉRENCE ULTÉRIEURE. VOUS DEVEZ LIRE CE GUIDE AVANT D'UTILISER LE BARBECUE!

## AHUMADOR DE BARRIL PARA CARBÓN VEGETAL

IMPORTANTE, LEER DETENIDAMENTE, CONSERVAR PARA REFERENCIA FUTURA. LEA EL MANUAL ANTES DEL USO!

## HOLZKOHLEFASSRAUCHER

WICHTIG: AUFMERKSAM LESEN UND GUT AUFBEWAHREN BITTE UNBEDINGT VOR GEBRAUCH DIE BEDIENUNGSANLEITUNG SORGFÄLTIG DURCHLESEN!

## FUMATORE DI CARBONE A BOTTE

IMPORTANTE: LEGGERE ATTENTAMENTE E CONSERVARE PER RIFERIMENTO FUTURO. LEGGERE IL MANUALE PRIMA DELL'USO.

For outdoor and household use only. Not for commercial use.  
Réservé à l'usage extérieur et résidentiel uniquement. Non destiné à un usage commercial.  
Solo para uso doméstico y en el exterior. No apto para uso comercial.  
Bitte nur im Freien und privat nutzen. Nicht für die gewerbliche Anwendung geeignet.  
Solo per uso domestico ed esterno. Non per uso commerciale.

**WARNING:** PLEASE READ THE ENTIRE MANUAL BEFORE INSTALLATION AND USE OF THIS APPLIANCE. FAILURE TO FOLLOW THESE INSTRUCTIONS COULD RESULT IN PROPERTY DAMAGE, BODILY INJURY OR EVEN DEATH. CONTACT LOCAL BUILDING OR FIRE OFFICIALS ABOUT RESTRICTIONS AND INSTALLATION INSPECTION REQUIREMENTS IN YOUR AREA.

**AVERTISSEMENT :** VEUILLEZ LIRE L'INTÉGRALITÉ DU MANUEL AVANT INSTALLATION ET UTILISATION DE CET APPAREIL. LE NON-RESPECT DE CES INSTRUCTIONS PEUT ENTRAÎNER DES DOMMAGES MATÉRIELS, DES DOMMAGES CORPORELS OU MÊME LA MORT. CONTACTEZ LES AUTORITÉS LOCALES COMPÉTENTES CONCERNANT LES RESTRICTIONS ET LES EXIGENCES D'INSPECTION EN VIGUEUR DANS VOTRE RÉGION.

**ADVERTENCIA:** LEA TODO EL MANUAL ANTES DE MONTAR Y USAR ESTA BARBACOA. SI NO SE SIGUEN ESTAS INSTRUCCIONES, PUEDEN PRODUCIRSE DAÑOS MATERIALES, LESIONES CORPORALES O INCLUSO LA MUERTE. PÓNGASE EN CONTACTO CON LOS ADMINISTRADORES DEL EDIFICIO O CON LOS BOMBEROS PARA CONSULTAR LAS RESTRICCIONES Y LOS REQUISITOS DE INSPECCIÓN DE LAS INSTALACIONES DE SU ZONA.

**ACHTUNG:** BITTE LESEN SIE DIE GESAMTE ANLEITUNG SORGFÄLTIG DURCH, BEVOR SIE DIESES GERÄT AUFSTELLEN UND BENUTZEN. DIE NICHTBEACHTUNG DIESER ANWEISUNGEN KANN ZU SACHSCHÄDEN, VERLETZUNGEN ODER SOGAR ZUM TOD FÜHREN. FÜR EINSCHRÄNKUNGEN SOWIE MONTAGE- UND KONTROLLAUFLAGEN IN IHRER REGION WENDEN SIE SICH AN DIE GEBÄUDE- ODER BRANDBEAUFTRAGTEN VOR ORT.

**AVVERTENZA:** LEGGERE L'INTERO MANUALE PRIMA DELL'INSTALLAZIONE E DELL'USO DI QUESTA APPARECCHIATURA. LA MANCATA OSSERVANZA DELLE ISTRUZIONI PUÒ CAUSARE DANNI ALLA PROPRIETÀ, LESIONI FISICHE O MORTE. CONTATTARE LE AUTORITÀ LOCALI COMPETENTI PER L'EDILIZIA O I VIGILI DEL FUOCO PER INFORMAZIONI SULLE RESTRIZIONI E SUI REQUISITI DI ISPEZIONE DEGLI IMPIANTI NELLA PROPRIA ZONA.



## SAFETY INFORMATION

# MAJOR CAUSES OF APPLIANCE FIRES ARE A RESULT OF POOR MAINTENANCE AND A FAILURE TO MAINTAIN REQUIRED CLEARANCE TO COMBUSTIBLE MATERIALS. IT IS OF UTMOST IMPORTANCE THAT THIS PRODUCT BE USED ONLY IN ACCORDANCE WITH THE FOLLOWING INSTRUCTIONS.

Please read and understand this entire manual before attempting to assemble, operate or install the product. This will ensure you receive the most enjoyable and trouble-free operation of your new charcoal smoker. We also advise you retain this manual for future reference.

### DANGERS AND WARNINGS

**You must contact your local home association, building or fire officials, or authority having jurisdiction, to obtain the necessary permits, mission or information on any installation restrictions, such as any unit being installed on a combustible surface, inspection requirements or even ability to use, in your area.**

1. A minimum clearance of 2m (78 inches) from combustible constructions to the sides of the unit must be maintained. **Do not install appliance on non-combustible floors, or floors protected with non-combustible surfaces unless proper permits and permissions are obtained by authorities having jurisdiction.** This appliance must not be placed under overhead combustible ceiling, overhang, awnings, parasol or gazebo. Do not use on decking or any other combustible surfaces such as dry grass, wood chips, leaf mulch, or decorative bark. Do not use this product in a tent, caravan, car, cellar, loft or boat. Keep your unit in an area clear and free from combustible materials, gasoline and other flammable vapors and liquids.

**Should a grease fire occur, close the lid until the fire is out. Do not throw water on the unit. Do not try to smother the fire. Use of an all-class (class ABC) approved fire extinguisher is valuable to keep on site. If an uncontrolled fire does occur, call the Fire Department.**

2. Do not use this smoker as a furnace. This product is intended for outdoor use only. Do not use indoors.

**Fire hazard: May emit hot embers while in use. Do not transport your unit while in use or while the unit is hot. Ensure the fire is completely out and that the unit is completely cool to the touch before moving.**

3. This product will become very hot, and serious injury may occur. Never leave a burning fire unattended. Keep young children and pets away while in use. It is recommended to use heat-resistant barbecue mitts or gloves when operating the unit. Do not use accessories not specified for use with this appliance.

**This appliance is not recommended for children, persons with reduced physical, sensory or mental capabilities, or lack of experience and knowledge, unless they are under direct supervision or instruction by a person responsible for their safety.**

4. After a period of storage, or non-use, inspect the unit prior to use for fatigue and damage, and replace as and when necessary. Clean before use. If the unit is stored outside during the rainy season or seasons of high humidity, unit should be dried out before performing any service or maintenance. Use a cover, if available.

5. It is highly recommended that you use lump charcoal in your smoker. It burns for longer and produces less ash, which can restrict the airflow. Do not use coal in this product. Charcoal not included.

**Do not use spirit, petrol, gasoline, lighter-fluid or kerosene for lighting or refreshing a fire in your unit. Keep all such liquids well away from the appliance when in use.**

**Use only firelighters complying to EN 1860-3**

## DISPOSAL OF ASHES

Ashes, or soot, should be placed in a metal container with a tight-fitting lid. The closed container of ashes should be placed on a non-combustible floor or on the ground, well away from all combustible materials, pending final disposal. When ashes are disposed by burial in soil, or otherwise locally dispersed, they should be retained in a closed container until all cinders have thoroughly cooled.

## CARBON MONOXIDE (“THE SILENT KILLER”)

Carbon monoxide is a colorless, odorless, tasteless gas produced by burning gas, wood, propane, charcoal or other fuel. Carbon monoxide reduces the blood’s ability to carry oxygen. Low blood oxygen levels can result in headaches, dizziness, weakness, nausea, vomiting, sleepiness, confusion, loss of consciousness or death. Follow these guidelines to prevent this colorless, odorless gas from poisoning you, your family, or others:

- See a doctor if you or others develop cold or flu-like symptoms while cooking or in the vicinity of the appliance. Carbon monoxide poisoning, which can easily be mistaken for a cold or flu, is often detected too late.
- Alcohol consumption and drug use increase the effects of carbon monoxide poisoning.

Carbon monoxide is especially toxic to mother and child during pregnancy, infants, the elderly, smokers, and people with blood or circulatory system problems, such as anemia, or heart disease.

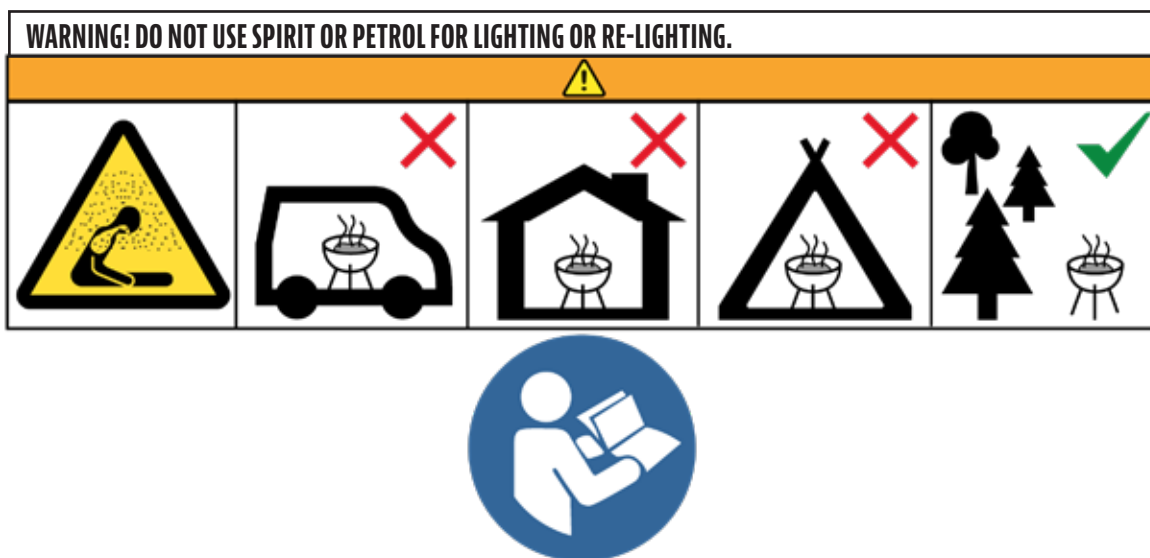



**COPYRIGHT NOTICE**

Copyright 2021. All right reserved. No part of this manual may be copied, transmitted, transcribed, stored in a retrieval system, in any form or by any means without expressed written permission of,

**DANSONS EUROPE**

11 Rue Galvani Paris, France 75017

**DANSONS NORTH AMERICA**

8877 North Gainey Center Drive, Scottsdale, AZ, USA 85258

**CUSTOMER CARE**

[www.pitboss-grills.com](http://www.pitboss-grills.com)

**TABLE OF CONTENTS**

- Safety Information ..... 2
- Operating Instructions ..... 5
  - Understanding Airflow ..... 5
  - First Use – Burn-Off ..... 5
  - Lighting Procedure ..... 5
  - Refueling Procedure ..... 5
  - Using Wood Pellets For Flavoring ..... 6
  - How To Use The Hanging Rack ..... 6
  - Extinguishing The Smoker ..... 7
- Care & Maintenance ..... 7
- Tips & Techniques ..... 8
- Troubleshooting ..... 9
- Replacement Parts ..... 10
- Warranty ..... 11

# OPERATING INSTRUCTIONS

## UNDERSTANDING AIRFLOW

The heart of your smoker lies in the relationship between the Air Intake Pipes and the Chimney dampers. Opening the dampers allows more air to flow through the body of the smoker, allowing the charcoal to burn very hot and create fiery embers. To cook at lower temperatures, keep the Air Intake Pipes and the Chimney dampers open only a small distance, allowing for minimal airflow and maximum heat retention in the Barrel Body of the smoker.

To ensure the smoker performs correctly, proper maintenance and cleanout of the Charcoal Basket are essential. If the smoker is not achieving the desired temperature, check to ensure that there is proper airflow from the Air Intake Pipes and that the Chimney is not blocked.

**TIP: The smoker can run efficiently over extended periods of time as long as there is dry and sufficient fuel, proper airflow, and the cooking components are clean.**

## FIRST USE – BURN-OFF

Before using your smoker for the first time with food, it is important to complete a burn-off. Starting the smoker and operating at a minimum of 177°C / 350°F with the lid closed for 30 to 40 minutes will burn-off the unit and rid it of any foreign matter.

## LIGHTING PROCEDURE

Ensure the smoker is positioned on a permanent, flat, level, heat-resistant non-flammable surface, away from flammable items. Position the smoker with a minimum of 2 m / 78 in overhead clearance and at least 2 m / 78 in clearance from combustible constructions.

1. Open the Lid of the Barrel Body.
2. Unlatch the Door Buckles and open the Charcoal Refill Door. Place some lighter cubes or solid firelighters into the Charcoal Basket and then load two or three handfuls of lump charcoal - filling the Charcoal Basket approximately 2/3 full.

**CAUTION: Do not use gasoline, spirit, lighter fluid, alcohol or other similar chemicals for lighting or relighting the fire.**

3. Light the lighter cubes or solid firelighters using a long-nosed lighter or safety matches. Once it has caught, slowly and carefully close the Charcoal Refill Door (using the Door Handle) and keep the Lid of the Barrel Body open for about 10 minutes to build a small bed of hot embers. Also, open the Air Intake Pipe dampers completely to encourage airflow.

**IMPORTANT: Do not cook before the fuel has a coating of ash. It is recommended that you do not stoke or turn the coals once they are alight. This allows the charcoals to burn more uniformly and efficiently.**

4. Allow the charcoal to heat up and adjust the Chimney and Air Intake Pipe dampers to reach your desired temperature.

## REFUELING PROCEDURE

With the Chimney closed, the smoker will stay at a high temperature for several hours. If you require a longer cooking time (e.g. when roasting a whole cut or slow-smoking), it may be necessary to add more charcoal.

1. Unlatch the Door Buckles and open the Charcoal Refill Door using heat-resistant gloves.
2. Carefully, add additional lump charcoal to the Charcoal Basket.
3. Close the Charcoal Refill Door and latch the Door Buckles to seal.

**IMPORTANT: Do not use spirit, petrol, gasoline, lighter-fluid or kerosene for lighting or refreshing a fire in your smoker. Also, do not attempt to add more fire starter into a fire that is already burning or into a hot Charcoal Basket. This may cause injury.**

## USING WOOD PELLETS FOR FLAVORING

Combining the use of charcoal and barbecue hardwood pellets in your smoker will add smoky flavoring to your foods. Hardwood pellets are known as the easiest fuel to use and come in a variety of different flavors - enhancing your smoking and cooking experience by using flavors like mesquite, hickory, and apple. Using hardwood pellets in your charcoal smoker will provide immense flavor without needing to closely monitor the air to fuel ratio like with wood chips or chunks.

Pit Boss® hardwood pellets produce less than 1% of ash, an entire 40 lb (18 kg) bag of pellets will only turn into half a cup of ash, which makes clean up a breeze. Pit Boss® hardwood pellets are made from 100% all-natural hardwood that is dried and ground into saw dust. The dust is then pressurized at extreme heat to create the compact pellets that are coated and held together with the wood's natural lighting.

1. Follow the lighting procedure like you normally would. Allow the charcoal to heat up and create the burning bed of hot embers to indicate the fire is hot.
2. Unlatch the Door Buckles and open the Charcoal Refill Door using heat-resistant gloves.
3. Carefully, add a blanket layer of hardwood pellets to the top of the burning coals of the Charcoal Basket.

**IMPORTANT: Do not add too many pellets as this will prevent proper airflow in the Charcoal Basket, causing the fire to burn out from lack of oxygen.**

4. Close the Charcoal Refill Door and latch the Door Buckles to seal.
5. Open the Chimney and Air Intake Pipe dampers to increase airflow until the pellets begin to smoke. Adjust the dampers to halfway open to allow the smoke to infuse the food inside the smoker.

**TIP: As a portion guide, half a cup of pellets should provide 30-40 minutes of smoke.**

## HOW TO USE THE HANGING RACK

Maximize space inside the smoker by using the Hanging Rack. Easily hang multiple racks of ribs, sausages, or any other meats using sturdy meat and/or sausage hooks. This allows the heat and infusing smoke to encircle the meat.

1. Remove the Cooking Grids and place the Hanging Rack on the highest position inside the Barrel Body.

**NOTE: Ensure the Heat Diffuser Plate remains inside the Barrel Body. It is used to disperse the direct heat from the Charcoal Basket, creating a more even heat distribution throughout the Barrel Body.**

2. Follow the lighting procedure like you normally would. Allow the charcoal to heat up and create the burning bed of hot embers to indicate the fire is hot. If hardwood pellets are desired for flavoring, add them at this time as well.
3. Prepare your meats for hanging:
  - Ribs - Find the large end of your rack (or slab) of ribs. On the big end, insert the meat hook directly center between the first and second bone, into the meat.
  - Sausages - Pierce the sausage link directly with the meat hook, or hang on smaller S-hooks by the casing or a tied string.
  - Whole Hens or Chickens - Truss or net your bird well to hang in a secure manner. The bird will start to get tender and bones will move during cooking. Hook through the next cavity into the breast, into the backbone or under the wishbone.
4. Adjust the dampers to be minimally open to allow the heat to stay inside the smoker. Open the Lid of the Barrel Body and place the hooked meats onto the Hanging Rack. Spread them out to allow for even airflow. Close the Lid of the Barrel Body as soon as all hooks are in place.
5. Allow the temperature to stabilize inside the smoker, and add fuel as needed.

**NOTE: Open the Lid of the Barrel Body and rotate the Hanging Rack every 20 minutes.**

## EXTINGUISHING THE SMOKER

1. When finished cooking and extinguishing the smoker, simply stop adding fuel. Close the Chimney and Air Intake Pipe dampers to allow the fire to die naturally by lack of oxygen.

**IMPORTANT: Do not use water to extinguish the charcoal as this could damage the Charcoal Basket.**

## CARE & MAINTENANCE

Any Pit Boss® unit will give you many years of flavorful service with minimum cleaning. Follow these cleaning and maintenance tips to service your smoker:

### 1. CHARCOAL COMPONENTS

- Clean out the Charcoal Basket and Charcoal Tray when a build-up of ash is found. Ensure that there are no signs of blockage of the holes of the Charcoal Basket.
- Clean out the Charcoal Refill Door and entry way to ensure it can open and close smoothly.

### 2. INSIDE SURFACES

- Using a grill cleaning brush, remove any food or build-up from the cooking grids. Best practice is to do this while they are still warm from a previous cook. Grease fires are caused by too much fallen debris on the cooking components of the smoker. Clean the inside of your Barrel Body on a consistent basis. In the event you experience a grease fire, keep the Lid of the Barrel Body closed to choke out the fire. If the fire does not go out quickly, carefully remove the food, and close all dampers until the fire is completely out. Lightly sprinkle baking soda, if available.
- Thoroughly clean the inner Barrel Body to remove any splatter or build-up of grease. Carefully remove all cooking components and turn the smoker on its side. Use a shop-vac to remove all ash and residue, then wash the inside walls and bottom using hot soapy water. Leave the smoker to dry completely before replacing cooking components.

### 3. OUTSIDE SURFACES

- Wipe down your smoker after each use. Use warm soapy water to cut the grease. Do not use oven cleaner, abrasive cleansers or abrasive cleaning pads on the outside surfaces as it may damage the paint finish. All painted surfaces are not covered under warranty, but rather are part of general maintenance and upkeep. For paint scratches, wearing, or flaking of the finish, all painted surfaces can be touched up using high heat BBQ paint.
- Use a cover to give your smoker complete protection! A cover is your best protection against weather and outside pollutants. When it is not in use or for long-term storage, keep the unit under a cover in a garage or shed.

### CLEANING FREQUENCY TIME TABLE (NORMAL USE)

ITEM	CLEANING FREQUENCY	CLEANING METHOD
Cooking Grids, Hanging Rack	After Each Grill Session	Burn Off Excess, Grill Cleaning Brush
Charcoal Basket, Charcoal Tray	Every 5-6 Grill Sessions	Warm Water & Mild Detergent
Dampers	Twice A Year	Tighten Using Wrench, Oil To Loosen
Inner Barrel Body	Twice A Year	Scrub Pad & Soapy Water
Outer Barrel Body, Side Shelves	As needed	Scrub Pad & Soapy Water

## TIPS & TECHNIQUES

Follow these helpful tips and techniques, passed on from Pit Boss® owners, our staff, and customers just like you, to become more familiar with your smoker:

### 1. *FOOD SAFETY*

- Keep everything in the kitchen and cooking area clean. Use different platters and utensils for the cooked meat than the ones you used to prepare or transport the raw meat out to the smoker. This will prevent cross contamination of bacteria. Each marinade or basting sauce should have its own utensil.
- Keep hot foods hot (above 60°C / 140°F), and keep cold foods cold (below 3°C / 37°F).
- A marinade should never be saved to use at a later time. If you are going to use it to serve with your meat, be sure to bring it to a boil before serving.
- Cooked foods should not be left out in the heat for more than an hour. Do not leave hot foods out of refrigeration for more than two hours.
- Defrost and marinade meats by refrigeration. Do not thaw meat at room temperature or on a counter top. Bacteria can grow and multiply rapidly in warm, moist foods. Wash hands thoroughly with hot, soapy water before starting any meal preparation and after handling fresh meat, fish, and poultry.

### 2. *COOKING PREPARATION*

- Be prepared, or **Mise en Place**. This refers to preparing the cooking recipe, fuel, accessories, utensils, and all ingredients you require at smoker side before you start cooking. Also, read the entire recipe, start to finish, before lighting the smoker.
- A BBQ floor mat is very useful. Due to food handling accidents and cooking spatter, a BBQ floor mat would protect a deck, patio, or stone platform from the possibility of grease stains or accidental spills.

### 3. *SMOKING TIPS AND TECHNIQUES*

- To infuse more smoke flavor into your meats, cook longer and at lower temperatures (also known as **low and slow**). Meat will close its fibers after it reaches an internal temperature of 49°C / 120°F. Misting, or mopping, are great ways to keep meat from drying out.
- While searing your meats, cook with the lid down. Always use a meat thermometer to determine the internal temperature of the foods you are cooking. Smoking foods can turn meats and poultry pink. The band of pink (after cooking) is referred to as a **smoke ring** and is highly prized by outdoor chefs.
- Sugar-based sauces are best applied near the end of cooking to prevent burning and flare-ups.
- Leave open space between the foods for proper heat flow. Food in a crowded smoker will require more cooking time.
- Use a set of long-handled tongs for turning meats, and a spatula for turning burgers and fish. Using a piercing utensil, such as a fork, will prick the meat and allow the juices to escape.
- Foods in deep casserole dishes will require more time to cook than a shallow baking pan.
- It's a good idea to put cooked food onto a heated platter, keeping the food warm. Red meats, such as steak and roasts, benefit from resting for several minutes before serving. It allows the juices that were driven to the surface by heat to ease back to the center of the meat, adding more flavor.



# TROUBLESHOOTING

Proper cleaning and maintenance will prevent common operational problems. When your smoker is operating poorly, or on a less frequent basis, the following troubleshooting tips may be helpful. For FAQ, please visit [www.pitboss-grills.com](http://www.pitboss-grills.com). You may also contact your local dealer or Customer Care for assistance.

**WARNING: Ensure the smoker is completely cooled prior to any inspection, cleaning, maintenance or service work. Failure to comply may result in serious injury or damage to your unit.**

PROBLEM	CAUSE	SOLUTION
Smoker Will Not Light	Damper Are Closed, Lack of Airflow	Ensure that both the Chimney and Air Intake Pipe dampers are open. The fire needs oxygen to catch. Once it has caught, leave the bottom vent and lid open for about 10 minutes to build a small bed of hot embers. Adjust dampers as needed.
	Incorrect Fuel Used	This smoker requires the use of lump charcoal. Follow Lighting Procedure, or call Customer Care for assistance, if required.
Smoker Will Not Achieve Or Maintain Stable Temperature	Smoker Gets Too Hot	Check the Chimney and Air Intake Pipe dampers. Mostly close both vents, and allow the smoker to smother with lack of oxygen. For low temperature cooking, use less fuel.
	Smoker Does Not Get Hot Enough	Check fuel level. The smoker may quickly lose fire if there is not enough charcoal in the Charcoal Basket. Add more fuel and leave both the Chimney and Air Intake Pipe dampers completely open. More oxygen and airflow will allow the fire to increase, burning more lump charcoal.
	Insufficient Airflow Through Barrel Body	Check Air Intake Pipe dampers for ash build-up or obstructions. Follow Care and Maintenance instructions for ash build-up. Check Chimney damper, and ensure it is working properly and airflow is not blocked. Follow Care and Maintenance instructions if dirty. Once all the above steps have been done, light the smoker and perform a burn-off.
Flare-Ups	Cooking Temperature Too High	Attempt cooking at a lower temperature. Grease does have a flash point. Keep the temperature under 176°C / 350°F when cooking highly greasy food.
	Grease Build-Up On Cooking Components	Follow Care and Maintenance instructions.
Dampers Will Not Adjust	Damper Stuck On Ash	Tap the damper lightly with a rubber hammer to loosen. If no improvement, call Customer Care.
Thermometer won't read	Broken Part	Thermometer needs to be replaced. Contact Customer Care for a replacement part.

# REPLACEMENT PARTS

Part#	Description
1	Chimney Lid (x1)
2	Chimney Stack (x1)
3	Barrel Lid (x1)
4	Upper Lid Hinge (x1)
5	Lower Lid Hinge (x1)
6	Lid Handle (x1)
7	Side Shelf (x2)
8	Side Shelf Bracket - Left (x2)
9	Side Shelf Bracket - Right (x2)
10	Thermometer (x1)
11	Hanging Rack (x1)
12	Cooking Grid (x3)
13	Heat Diffuser Plate (x1)
14	Upper Barrel Assembly (x1)
15	Lower Barrel Assembly (x1)
16	Door Axle (x1)
17	Charcoal Basket (x1)
18	Charcoal Tray (x1)
19	Charcoal Refill Door (x1)
20	Door Handle (x1)
21	Door Buckle (x2)
22	Air Intake Pipe (x2)
23	Air Intake Silicone Pad (x2)
24	Body Bracket Handle (x2)
25	Body Bracket (x1)
26	Body Bracket Spacer (x4)
27	Foot Gasket (x4)
28	Refill Door Caster - A (x1)
29	Refill Door Caster - B (x1)
30	Wheel (x1)

Part#	Description
A	Wheel Axle Pin (x2)
B	Wheel Washer (x2)
C	Wheel Locking Pin (x2)
D	Screw (x4)
E	Screw (x14)
F	Locking Washer (x4)
G	Washer (x4)
H	Screw (x8)
I	Step Screw (x4)

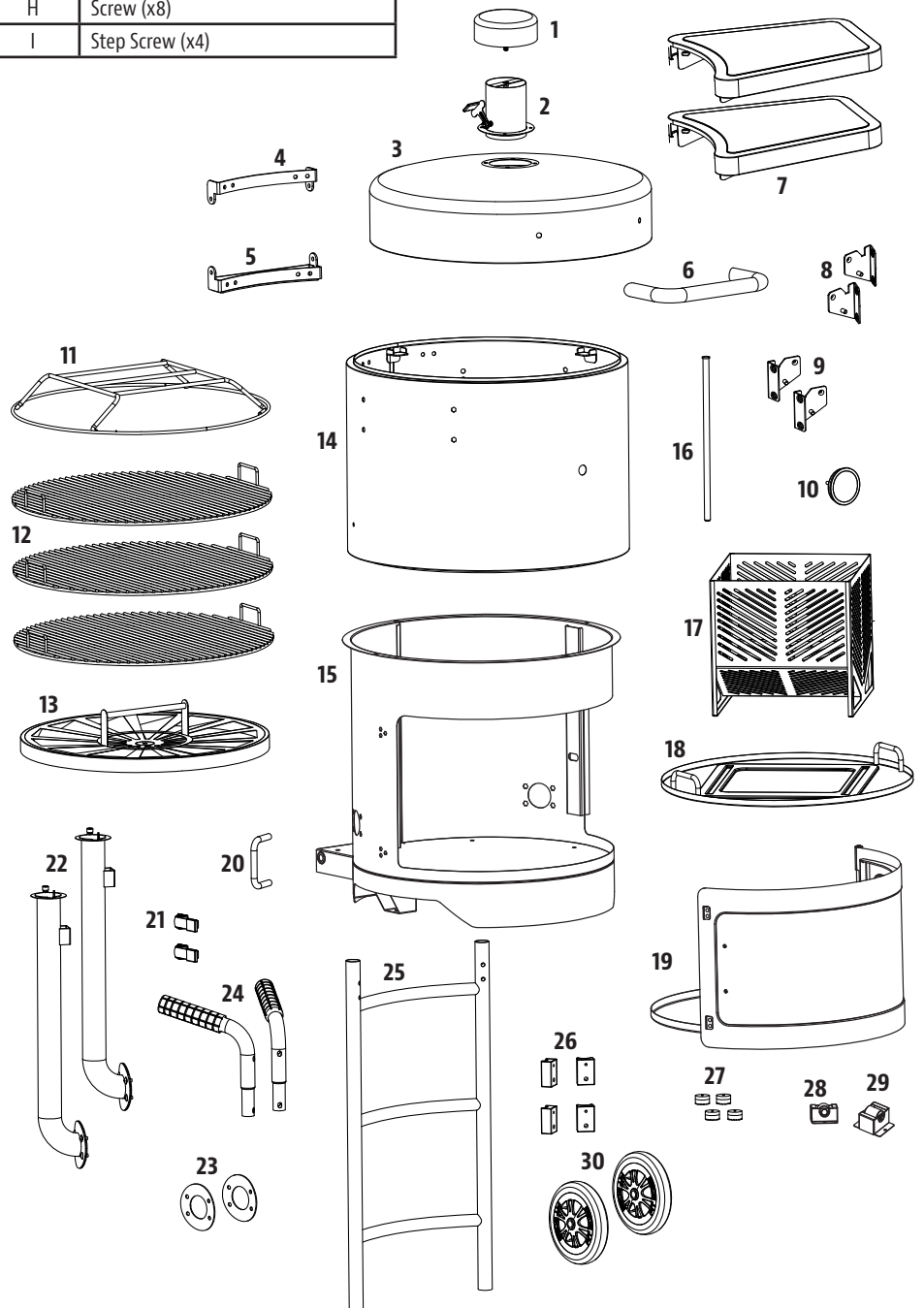
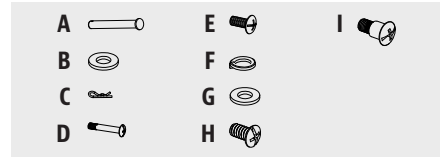

NOTE: Due to ongoing product development, parts are subject to change without notice.

# WARRANTY

## CONDITIONS

All charcoal smokers by Pit Boss® Grills, manufactured by Dansons, carry a limited warranty from the date of sale by the original owner. The warranty coverage begins on the original date of purchase and proof of date of purchase, or copy of original bill of sale, is required to validate the warranty. Customers will be subject to parts, shipping, and handling fees if unable to provide proof of the purchase or after the warranty has expired.

Dansons carries a five (5) year warranty against defects and workmanship on all parts. Dansons warrants that all part(s) are free of defects in material and workmanship, for the length of use and ownership of the original purchaser. Warranty does not cover damage from wear and tear, such as scratches, dents, dings, chips or minor cosmetic cracks. These aesthetic changes of the smoker do not affect its performance. Repair or replacement of any part does not extend past the limited warranty beyond the five (5) year from date of purchase. During the term of the warranty, Dansons' obligation shall be limited to furnishing a replacement for defective and/or failed components. As long as it is within the warranty period, Dansons will not charge for repair or replacement for parts returned, freight prepaid, if the part(s) are found by Dansons to be defective upon examination. Dansons shall not be liable for transportation charges, labor costs, or export duties. Except as provided in these conditions of warranty, repair or replacement of parts in the manner and for the period of time mentioned heretofore shall constitute the fulfillment of all direct and derivate liabilities and obligations from Dansons to you.

Dansons takes every precaution to utilize materials that resist rust. Even with these safeguards, the protective coatings can be compromised by various substances and conditions beyond Dansons' control. High temperatures, excessive humidity, chlorine, industrial fumes, fertilizers, lawn pesticides and salt are some of the substances that can affect metal coatings. For these reasons, the warranty does not cover rust or oxidization, unless there is loss of structural integrity on the smoker components. Should any of the above occur, kindly refer to the care and maintenance section to maintain the finish of your smoker and prolong its lifespan. Dansons recommends the use of a full length protective cover when the smoker is not in use. This warranty is based on normal domestic use and service of the unit and neither limited warranty coverage's apply for a unit which is used in commercial applications.

## EXCEPTIONS

There is no written or implied performance warranty on Pit Boss® Grills, as the manufacturer has no control over the installation, operation, cleaning, maintenance or the type of fuel burned. This warranty will not apply nor will Dansons assume responsibility if your appliance has not been installed, operated, cleaned and maintained in strict accordance with this owner's manual. Any use of gas not outlined in this manual may void the warranty. The warranty does not cover damage or breakage due to misuse, improper handling or modifications. Dansons does not accept responsibility, legal or otherwise, for the incidental or consequential damage to the property or persons resulting from the use of this product. Whether a claim is made against Dansons based on the breach of this warranty or any other type of warranty expressed or implied by law, the manufacturer shall in no event be liable for any special, indirect, consequential or other damages of any nature whatsoever in excess of the original purchase of this product. All warranties by manufacturer are set forth herein and no claim shall be made against manufacturer on any warranty or representation. Some states do not allow the exclusion or limitation of incidental or consequential damages, or limitations of implied warranties, so the limitations or exclusions set forth in this limited warranty may not apply to you. This limited warranty gives you specific legal rights and you may have other rights, which vary from state to state.

## CONTACT CUSTOMER CARE

To order replacement parts, please contact your local Pit Boss® Grills dealer or visit our online store at: [www.pitboss-grills.com](http://www.pitboss-grills.com).

## WARRANTY SERVICE

Contact your nearest Pit Boss® Grills dealer for repair or replacement parts. Dansons requires proof of purchase to establish a warranty claim; therefore, retain your original sales receipt or invoice for future reference. The serial and model number of your Pit Boss® can be found directly on the unit. Record numbers below as the label may become worn or illegible.

---

MODEL

---

SERIAL NUMBER

---

DATE OF PURCHASE

---

AUTHORIZED DEALER